

comercial  *paperera*

MATERIALS I SERVEIS PER A L'OFICINA

Tot i molt a prop

972 406 301

comandes@comercialpaperera.com

www.comercialpaperera.com

Fitxa tècnica - Codi 41751



TERRA

TERRA



TERRA is a modern lamp with fine and clean lines. Extra-flat head and base. Economic and functional; It has 4 light intensities and offers optimal visual comfort. Swivel and reclining arms and head. Touch switch on the base to choose its light intensity among 4.



- 4 Levels Adjustable Brightness: Touch switch offers 4 levels of white color. Choose the most appropriate light intensity throughout the day to best meet your needs.
- Flexibility: with its +/-120° movable head, its 90° adjustable arm and its +/-30° rotating base (right and left), this lamp can adopt an infinite number of positions. In addition, its base is specially designed to provide excellent stability.
- Modern design: with its fine and clean lines, its head does not exceed 1 cm in thickness which gives it an elegant character.
- The + product: Ideal for storing it in a drawer or a bag to accompany you when you travel (office, meeting room, traveling).
- Desk lamp using latest generation LEDs: saving energy. It has a lifespan of 40,000 hours Protects your eyes: stable light without flickering or glare. Low visual stress after prolonged use, ideal for working, reading or studying, at home or in the office.

Warranty: 2 years

Max height: 40 cm/ minimum height: 15 cm

Materials: recyclable aluminum head, arms and base / ABS plastic tips



Professional replaceable light source (LED only)

Characteristics

Measurement in Lux on the worktop in top view at 35 cm:

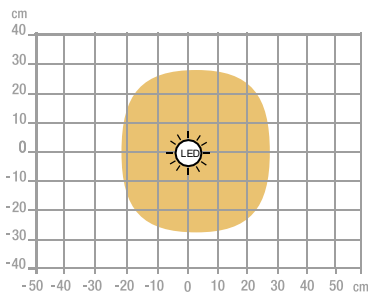

> 500 Lux

< 500 Lux

Measurement in Lux on the worktop in profile view at 35 cm:

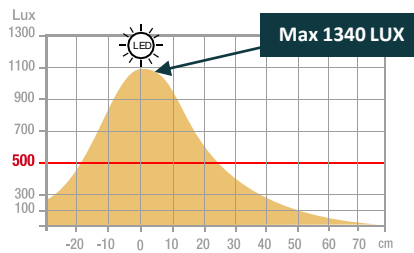

Measurement in nanometers of the light spectrum

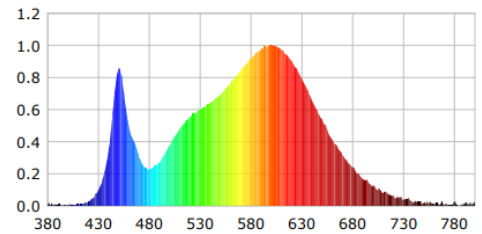

- 0 No-risk
- 1 Low-risk
- 2 Moderate-risk
- 3 High-risk

SAP no.	400077409
EAN code	3595560012855
Colors	Grey metal
Luminous flow	680
Lux at 35cm	1145
Lm/W	97
Color T° (K)	3500
CRI	83
Source Lifetime (h)	40 000
Energy consumption (kWh/1000 h)	7
USB Port	No
Inductive charger	No
Net weight (kg)	1,19

OUR CSR COMMITMENTS

1. All our lighting are **100% repairable** thus limiting planned obsolescence.
2. Reduce our carbon footprint through our **ECO-DESIGN THINKING** approach.
3. Contribute to the preservation of the planet's natural resources by promoting the use of **recycled materials**.
4. Optimize our packaging to control our **transport costs**.
5. Highlight the **talent of our employees** by ensuring social equality.

Energy class

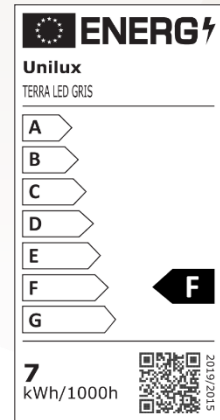

OUR EXPERTISE

1-Why use auxiliary lighting?

We are regularly subjected to constant artificial lighting in the office, which takes no account of our biological rhythms. Poor lighting quality can cause headaches, sleep disorders and loss of concentration. According to a recent study, only 34% of offices achieve the level of illumination of 500 lux recommended by Occupational Medicine in accordance with DIN EN 12464-1*.

2-How to light your workspace?

- Position the lamp head at least 35 cm above the worktop. work surface.
- Place the lamp on the opposite side to the hand that is holding the mouse or writing.
- Use lamps with asymmetrical lighting to reduce eyestrain, which can lead to eye irritation, headaches, loss of concentration, reduced productivity, etc.
- Position the lamp so that it is easy to adjust and so that the light is in the right place.
- Avoid reflections from shiny surfaces.
- Limit direct glare from bright light in the field of vision and indirect glare from bright light in the field of vision. in the field of vision and indirect glare from the reflection of light from the reflection of light in the field of vision, on a work surface walls or objects.

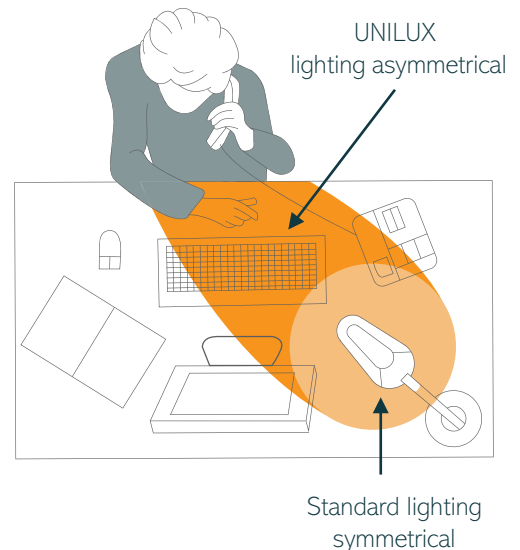

OUR CERTIFICATIONS

Unilux is committed to an eco-responsible approach and ensures that its products respect this commitment. Indeed, we are very concerned about current environmental issues and we aspire to respond as best as possible to the concerns of our consumers on this subject. Sustainable development is at the heart of our strategy and we act for the environment. You will find below the different certifications that Unilux has and that prove its environmental commitment.





UNILUX

* DIN EN 12464-1 (DIN 5035-1): European standard which determines the lighting requirements for workstations in closed places, these satisfying the needs of comfort and visual performance. DIN EN 12464-1 replaced DIN 5035-1

USER GUIDE

i

 x1

 1 min



 www.my-unilux.com

+

(A) x1

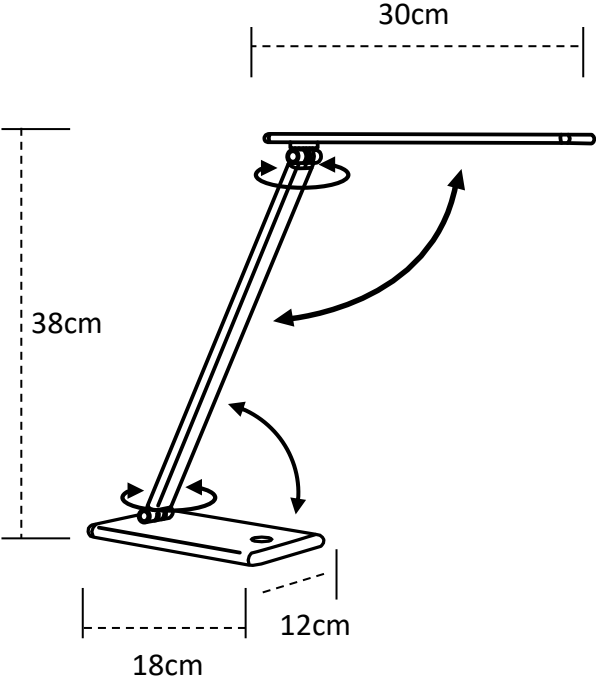
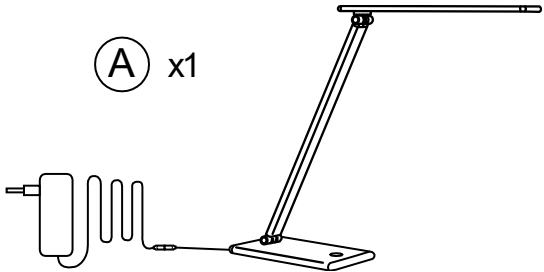

30cm

38cm

18cm

12cm

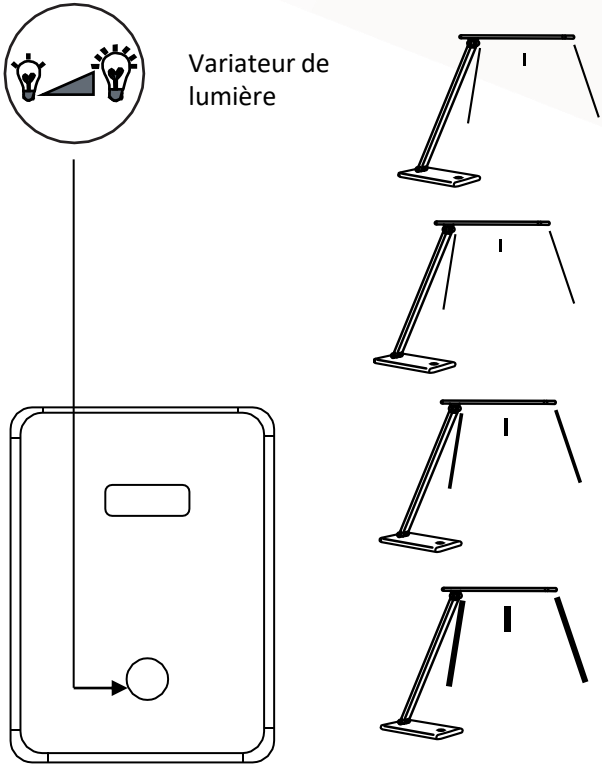
 Variateur de lumière

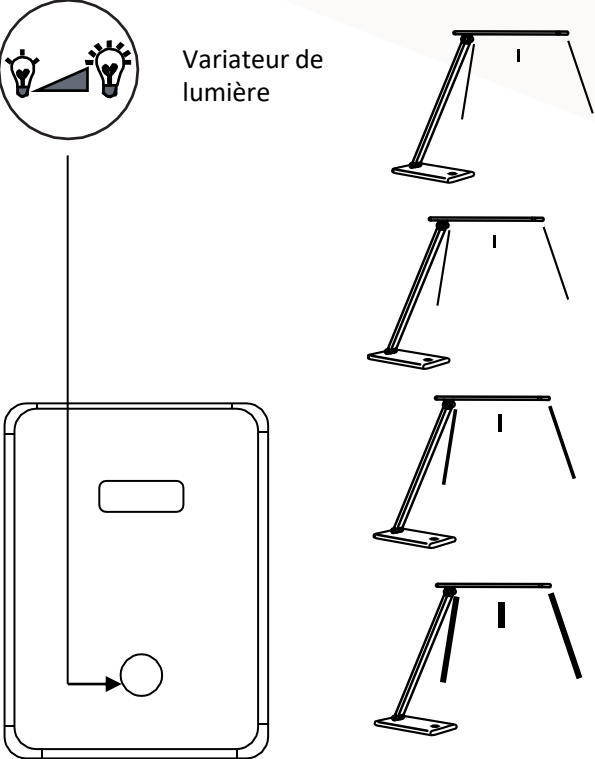

1

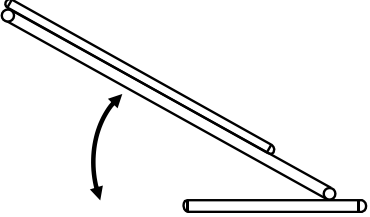

2

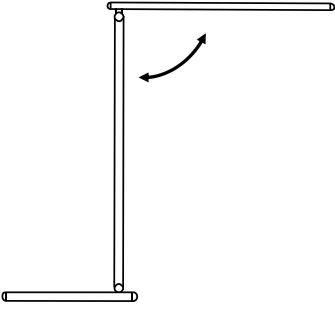

3

