

VISUALLINE



PIZARRAS CABALLETE

RD-605V22

Pizarra trípode metálica y magnética de gran estabilidad, apta para escritura con rotuladores de borrado en seco. Admite bloc de papel universal. Sus pies plegables permiten un almacenamiento óptimo. Fácil montaje.



VER VIDEO





VER VIDEO



Medidas / Sizes (cm)

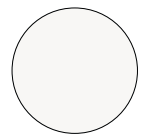

(RAL 9003)

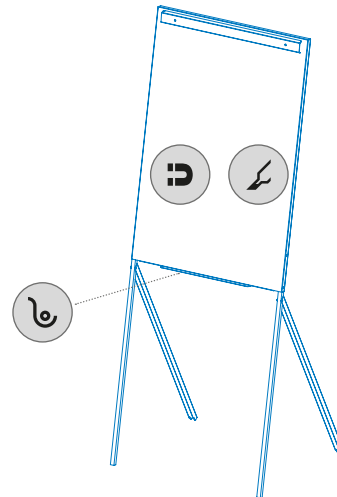
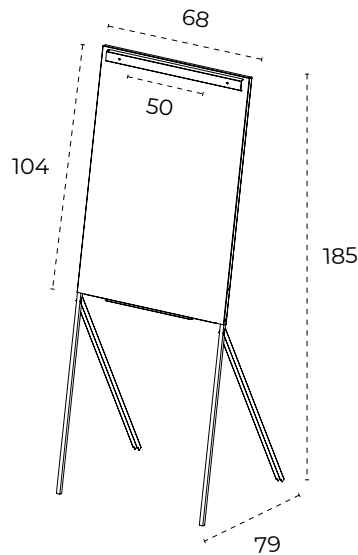

Ref.	Descripción	Uds.	cm (superficie)	cm (producto)	cm (packaging)	kg / m ³ (packaging)
59600	Pizarra de conferencias plegable metálica lacada blanca	1	68 x 104	68 x 185 x 79	120 x 69 x 4	13 kg / 0,033 m ³

www.comercialpaperera.com - Tel. 972 406 301

C/ Can Pau Birol, 14 - Pol. Ind. Mas Xirgu - 17005 Girona - comandes@comercialpaperera.com